

Motor de Partida M90R3553SE



Mercedes Benz

Caraterísticas

Tensão nominal [V]	24
Potência [kW]	6,0
Sentido de rotação	horário
Inclinação de montagem	330
Ângulo de fecho	127
Número de dentes	13
Tipo de contatos	G </td
Peso [Kg]	10,0

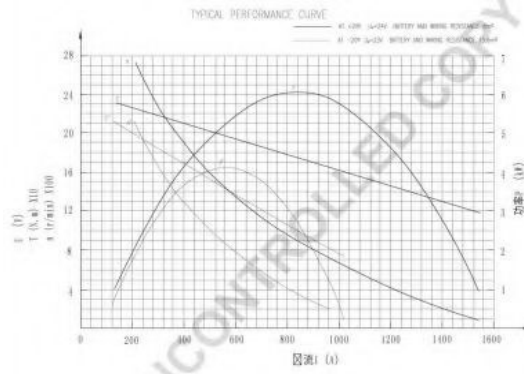
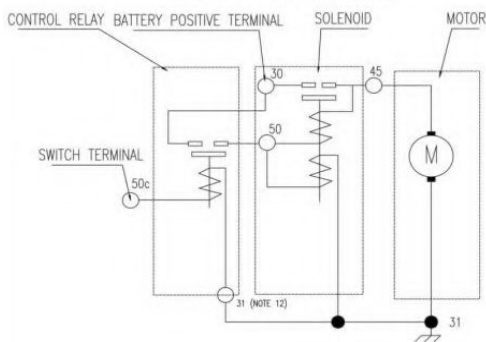
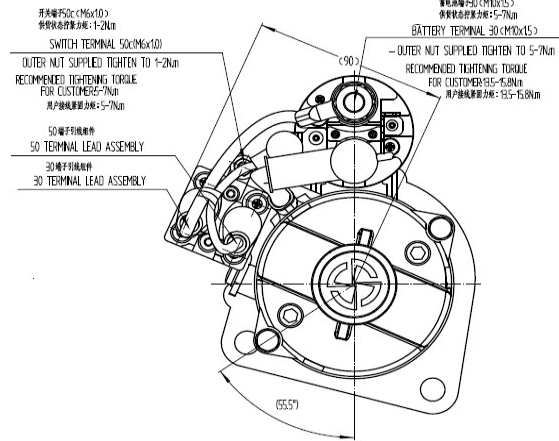
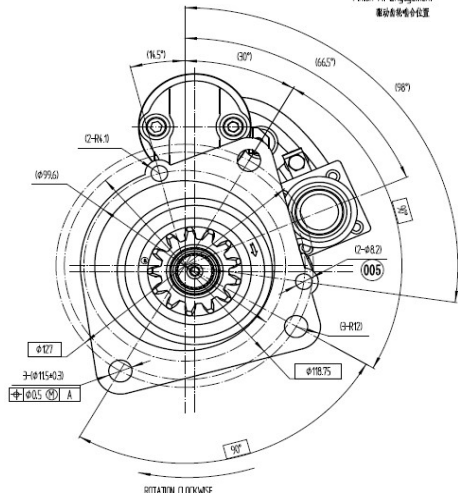
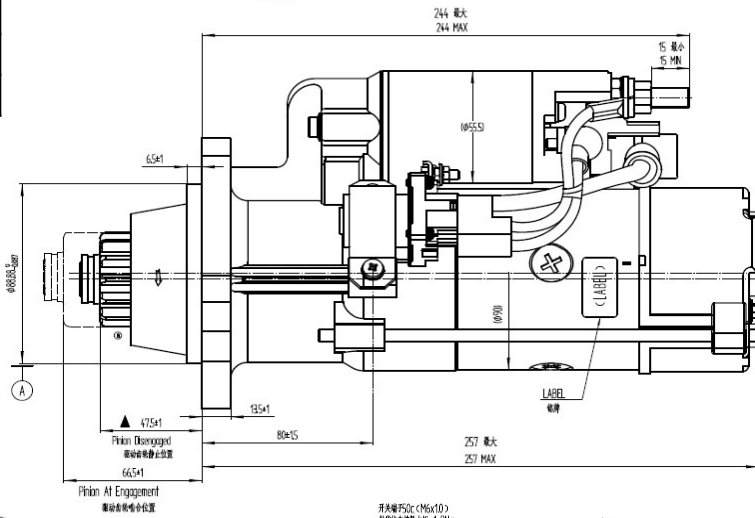

Motor de Partida M90R3553SE





Cross-reference

DELCO REMY	DRS0541
HOLGER CRISTIANSEN	114086
MERCEDES BENZ	A0061514801
	A0061516801
	A0071510801
MITSUBISHI	M9T64371
	M9T65271
	M9T66171

Motor de Partida M90R3553SE



Aplicações

Marca	Veículo	Motor
MERCEDES BENZ  Mercedes-Benz	AXOR 1933 / 2533 	OM926 LA
	Ônibus OF-1724 / OF-1721 / OF-1519 OH-1519 / OH-1621 	OM924 LA